

## Features :

- Support 10GBASE-LR/10GBASE-LW/10G Fiber Channel application
- Compliant to SFP+ Electrical MSA SFF-8431
- Compliant to SFP+ Mechanical MSA SFF-8432
- Multi rate of up to 11.3Gbps
- Transmission distance up to 10km and 40KM
- +3.3V single power supply
- Low power consumption
- Operating case temp : 0~+70°C
- RoHS 6/6 compliant

## Absolute Maximum Ratings

Table 1- Absolute Maximum Ratings

Parameter	Symbol	Min.	Typical	Max.	Unit	Notes
Supply Voltage	V <sub>CC3</sub>	-0.5	-	+3.6	V	
Storage Temperature	T <sub>s</sub>	0	-	+70	°C	
Operating Humidity	RH	+5	-	+95	%	

## Recommended Operating Conditions

Table 2- Recommended operating Conditions

Parameter	Symbol	Min.	Typical	Max.	Unit	Notes
Operating Case Temperature	T <sub>C</sub>	0	-	+70	°C	
Power Supply Voltage	V <sub>CC</sub>	3.14	3.3	3.47	V	
Power Supply Current	I <sub>CC</sub>	-	-	300	mA	
Power Dissipation	P <sub>d</sub>	-	-	1.0	W	
Bit Rate	BR	-	10.3125	-	Gbps	

## Electrical Characteristics

Table 3- Electrical Characteristics

**SFP+ 10G Bi-Di 60KM**  
**SOSP-2399-60**

Parameter	Symbol	Min.	Typ.	Max.	Units	Notes
<b>Transmitter</b>						
Differential Data Input Swing	$V_{in,P-P}$	120	-	850	mV <sub>PP</sub>	
Input Differential Impedance	$Z_{IN}$	80	100	120	$\Omega$	
Tx_Fault	Normal Operation	$V_{OL}$	0	-	0.8	V
	Transmitter Fault	$V_{OH}$	2.0	-	$V_{CC}$	V
Tx_Disable	Normal Operation	$V_{IL}$	0	-	0.8	V
	Laser Disable	$V_{IH}$	2.0	-	$V_{CC}+0.3$	V
<b>Receiver</b>						
Differential Date Output	$V_{out}$	100	-	800	mV	
Output Differential Impedance	$Z_D$	80	100	120	$\Omega$	
Output Rise Time(20-80%)	$T_R$	24	-	-	ps	
Output Fall Time (20-80%)	$T_F$	24	-	-	ps	
Rx_LOS	Normal Operation	$V_{OL}$	0	-	0.8	V
	Lose Signal	$V_{oH}$	2.0	-	$V_{CC}$	V

## Optical Characteristics

Table 4-Optical Characteristics  
SOSP-2399-60 (10G 1270TX 1330RX 10-60KM)  
SOSP-3299-60 (10G 1330TX 1270RX 10-60KM)

Parameter	Symbol	Unit	Min.	Typ.	Max.	Notes
<b>Optical transmitter Characteristics</b>						
Bit Rate	BR	Gbps	9.953	10.3125	11.3	
Center Wavelength Range	$\lambda_c$	nm	1250	1270	1290	SOBP-2396-10L
			1310	1330	1350	SOBP-3296-10L
Average Launch power Tx_off	$P_{off}$	dBm	-	-	-45	
Launch Optical Power	$P_0$	dBm	-7.5	-	0	1
Extinction Ratio	ER	dB	3.5	-	-	
Jitter P-P	JP	ps	-	-	27	
Jitter RMS	JR	ps	-	-	5	

**SFP+ 10G Bi-Di 60KM**  
**SOSPB-2399-60**

Optical Rise/Fall time	Tr/tf	ps	-	-	100	
Eye Diagram	Compliant With IEEE 802.3-2005					
<b>Optical receiver Characteristics</b>						
Bit Rate	BR	Gbps	9.953	10.3125	11.3	
Receiver Sensitivity	RS	dBm	-	-	-14	2
Overload Input Optical Power	P <sub>IN</sub>	dBm	0	-	-	2
Center Wavelength Range	$\lambda_c$	nm	1310	1330	1350	SOBP-2396-10L
			1250	1270	1290	SOBP-3296-10L
LOS	LOS <sub>D</sub>	dBm	-	-	-15	
	LOS <sub>A</sub>		-24.5	-	-	
LOS Hysteresis		dB	0.5	-	-	

**SOSPB-2399-40 (10G 1270TX 1330RX 20-40KM)**  
**SOSPB-3299-40 (10G 1330TX 1270RX 20-40KM)**

Parameter	Symbol	Unit	Min.	Typ.	Max.	Notes
<b>Optical transmitter Characteristics</b>						
Bit Rate	BR	Gbps	9.953	10.3125	11.3	
Center Wavelength Range	$\lambda_c$	nm	1250	1270	1290	SOBP-2396-40L
			1310	1330	1350	SOBP-3296-40L
Average Launch power Tx <sub>off</sub>	P <sub>off</sub>	dBm	-	-	-45	
Launch Optical Power	P <sub>0</sub>	dBm	1	-	6.5	1
Extinction Ratio	ER	dB	3.8	-	-	
Jitter P-P	JP	ps	-	-	27	
Jitter RMS	JR	ps	-	-	5	
Optical Rise/Fall time	Tr/tf	ps	-	-	100	
Eye Diagram	Compliant With IEEE 802.3-2005					
<b>Optical receiver Characteristics</b>						
Bit Rate	BR	Gbps	9.953	10.3125	11.3	
Receiver Sensitivity	RS	dBm	-	-	-14	2
Overload Input Optical Power	P <sub>IN</sub>	dBm	0	-	-	2
Center Wavelength Range	$\lambda_c$	nm	1310	1330	1350	SOBP-2396-40L
			1250	1270	1290	SOBP-3296-40L

## SFP+ 10G Bi-Di 60KM SOSPB-2399-60

LOS	LOS <sub>D</sub>	dBm	-	-	-15	
	LOS <sub>A</sub>		-24.5	-	-	
LOS Hysteresis		dB	0.5	-	-	

Note:

1. Coupled into 9/125 SMF.
2. Measured with PRBS 2<sup>31</sup>-1 test pattern @10.3125Gbps.BER=10E-12

### Recommended interface Circuit

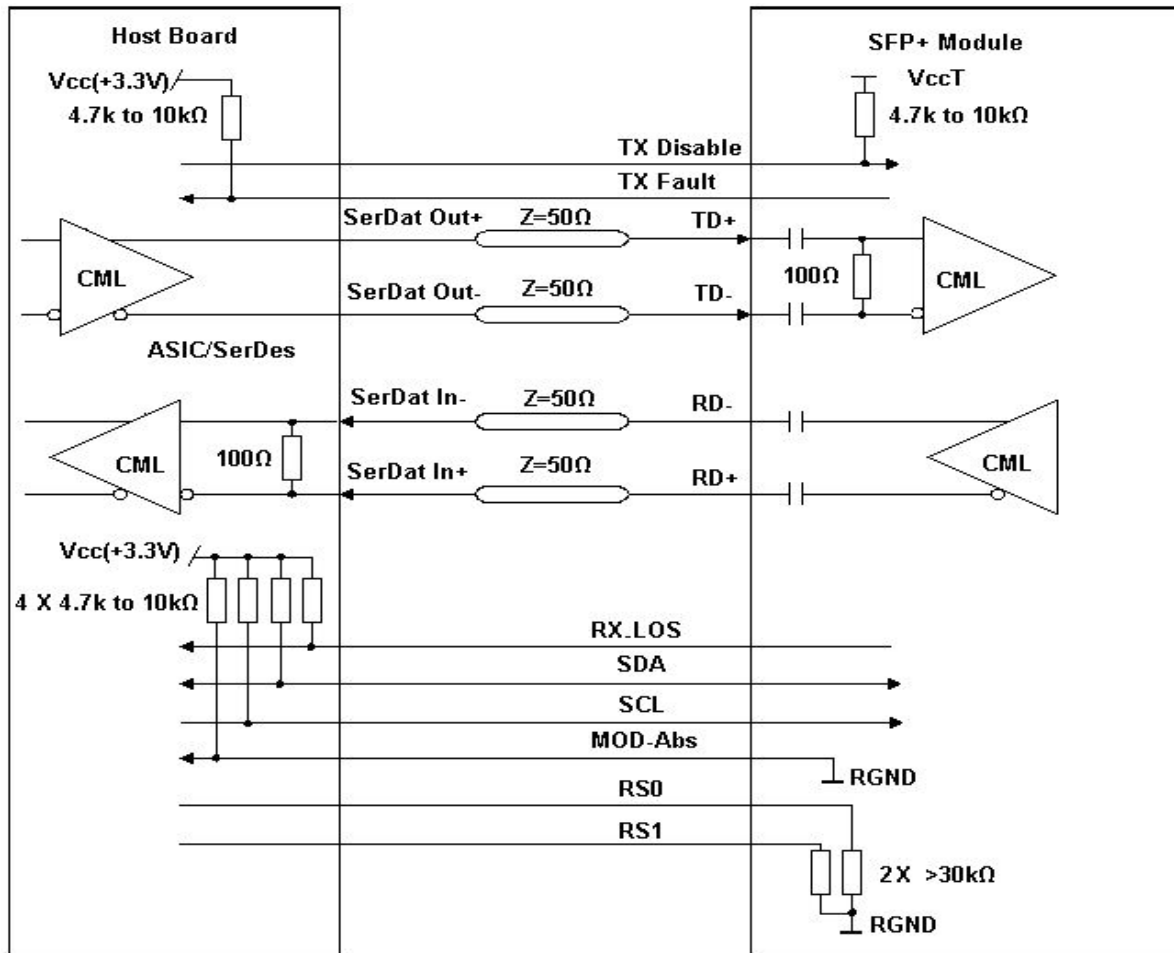

Figure 1, Recommended Interface Circuit

## Recommended Host Board Power Supply Circuit

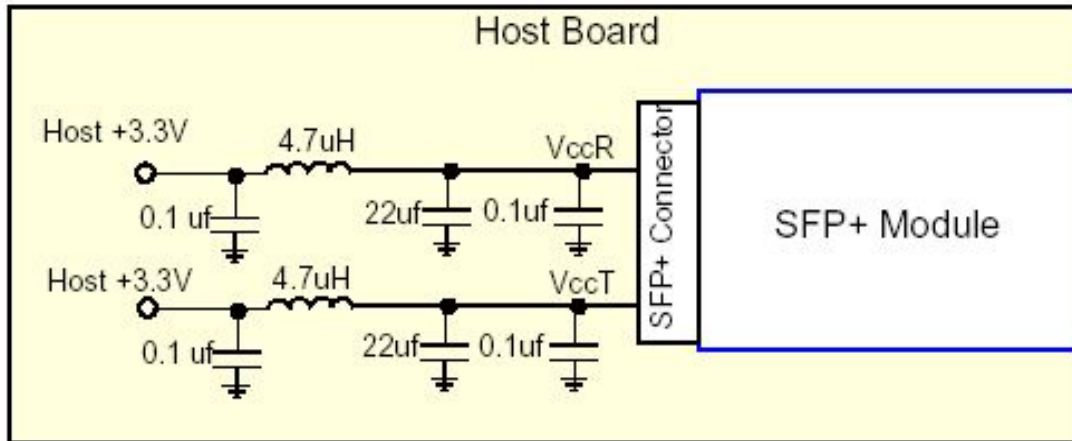

Figure 2, Recommended Host Board Power Supply Circuit

## Pin arrangement

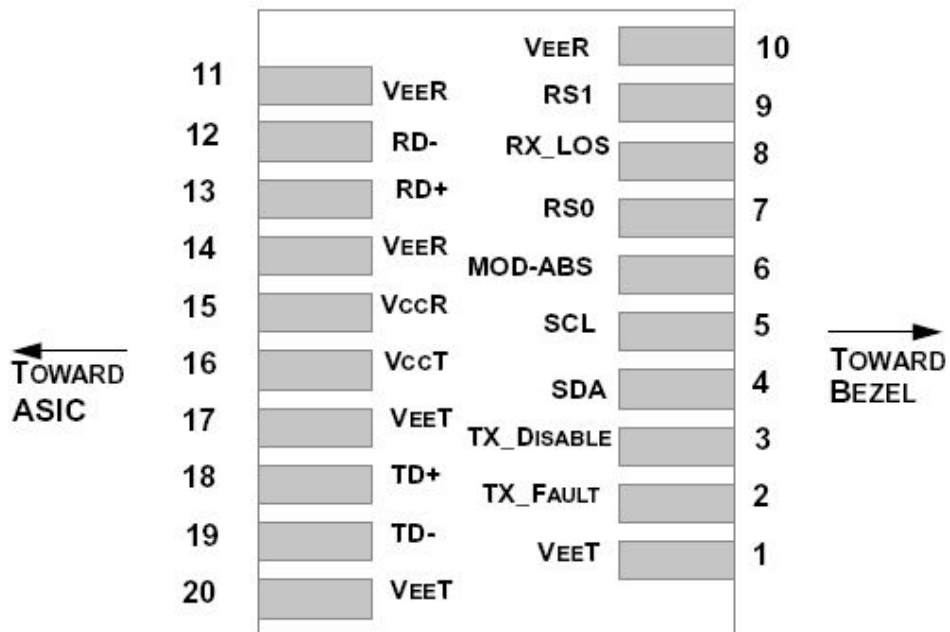

Figure 3, Pin View

**Table 5-Pin Function Definitions**

Pin	Symbol	Name/Description	Notes
1	VEET	Module Transmitter Ground	1
2	TX_FAULT	Module Transmitter Fault	2
3	TX_DISABLE	Transmitter Disable; Turns off transmitter laser output	3
4	SDA	2-Wire Serial Interface Data Line (MOD-DEF2)	
5	SCL	2-Wire Serial Interface Clock (MOD-DEF1)	
6	MOD_ABS	Module Absent, connected to V <sub>EE</sub> T or V <sub>EE</sub> R in the	2
7	RS0	Rate Select 0, optionally controls SFP+ module receiver as the following when HIGH input Bit Rate>4.25 Gbps	
8	RX_LOS	Receiver Loss of Signal Indication (in FC designated as RX_LOS, in SONET designated as LOS,	2
9	RS1	Rate Select 1, optionally controls SFP+ module transmitter as the following when HIGH input Bit Rate>4.25 Gbps and when LOW input Bit Rate ≤4.25 Gbps.	
10	V <sub>EE</sub> R	Module Receiver Ground	1
11	V <sub>EE</sub> R	Module Receiver Ground	1
12	RD-	Receiver Inverted Data Output	
13	RD+	Receiver Non-Inverted Data Output	
14	V <sub>EE</sub> R	Module Receiver Ground	1
15	V <sub>CC</sub> R	Module Receiver 3.3 V Supply	
16	V <sub>CC</sub> T	Module Transmitter 3.3 V Supply	
17	V <sub>EE</sub> T	Module Transmitter Ground	1
18	TD+	Transmitter Non-Inverted Data Input	
19	TD-	Transmitter Inverted Data Input	
20	V <sub>EE</sub> T	Module Transmitter Ground	1

**Note:**

1. The module ground pins are isolated from the module case.
2. The pins shall be pulled up with 4.7K-10Kohms to a voltage between 3.14V and 3.46V on host board.
3. The pin is pulled up to VCCT with a 4.7K-10KΩ resistor in the module.

## Digital Diagnostic Memory Map

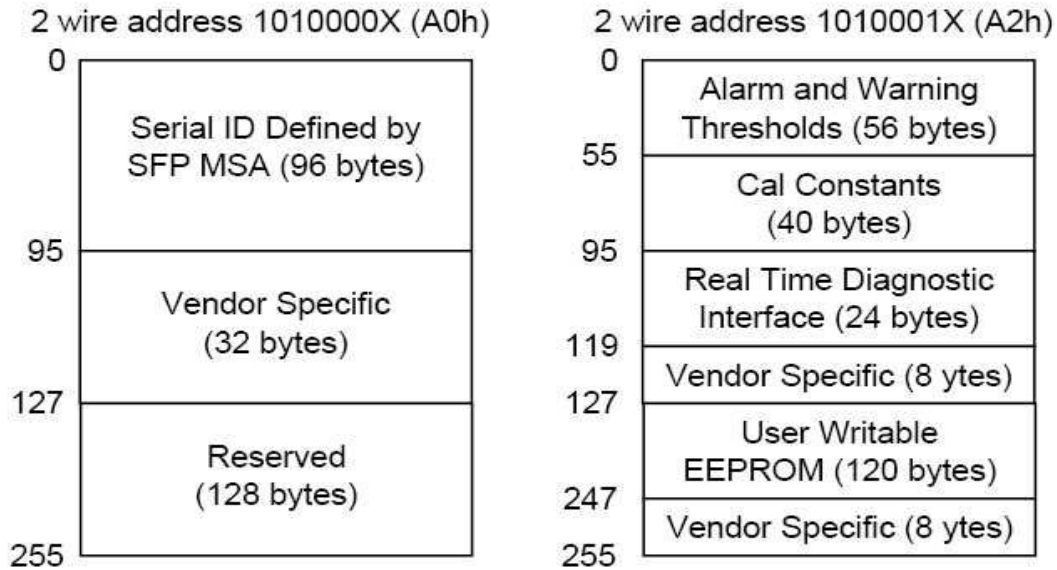

Figure 4, Memory Map

## Mechanical Diagram

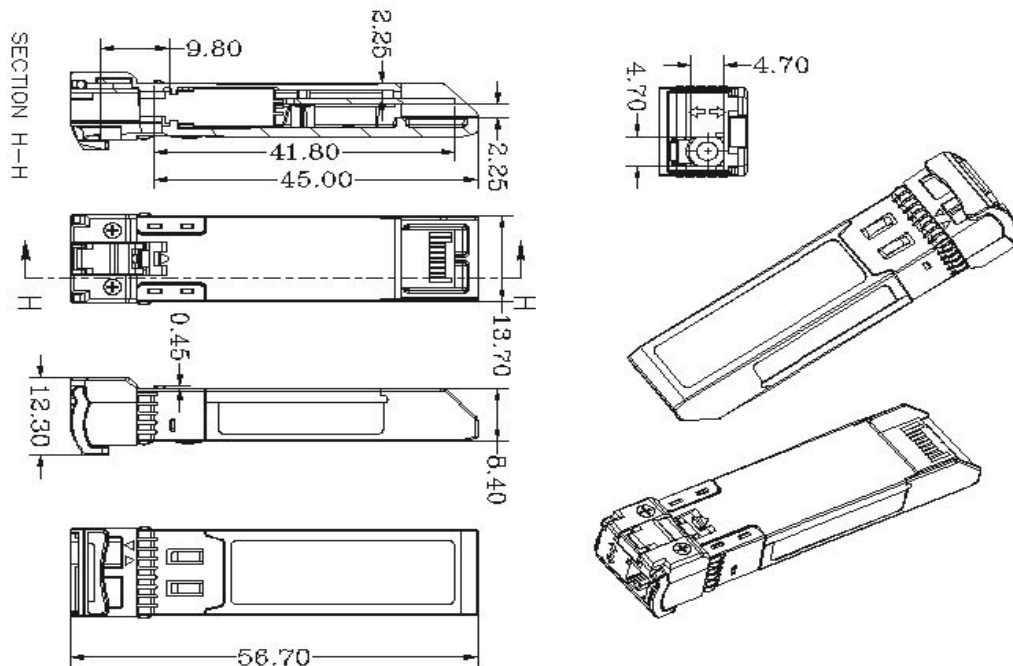

Figure 5, Mechanical Diagram

## Order Information

Table 6-Order Information

Part No.	Bit Rate (Gbps)	Laser TX(nm)	Laser RX(nm)	Fiber Type	Distance	Connector
SOSPB-2399-60	10.3125	1270	1330	SMF	20-40KM	Simplex LC Receptacle
SOSPB-3299-60	10.3125	1330	1270	SMF	20-40KM	Simplex LC Receptacle

### ● Notice

SINOVO reserves the right to make changes to or discontinue any optical link product or service identified in this publication, without notice, in order to improve design and/or performance. Applications that are described herein for any of the optical link products are for illustrative purposes only. SINOVO makes no representation or warranty that such applications will be suitable for the specified use without further testing or modification.

### ● Contact

Shenzhen Sinovo Telecom Co.,Ltd  
 Tel:+86(0)0755-32959919 Fax:+86(0)755 32959918  
 Email: sales@sinovocorp.com  
 Web:www.sinovocorp.com  
 Factory ADD:5/F Chuang Park,Taoyuan Street Baoan District,Shenzhen,China  
 Head Quarter:11/F, Taibang Technology Building,Gaoxin South 4<sup>th</sup>,Science and Technology Park South,Nanshan,Shenzhen,China 518040